

Appendix U

Light Trailer Requirements - Compliance with VSB1

Background

All new trailers (including imported trailers), not exceeding 4500kg Aggregate Trailer Mass (ATM), presented for registration in Tasmania must comply with requirements of the National Code of Practice for Building Small Trailers – Vehicle Standards Bulletin (VSB)1 – as published by the Commonwealth Department of Infrastructure, Transport, Regional Development and Local Government.

VSB1 summarises the requirements for compliance with Australian Design Rules (ADRs).

In verifying compliance with VSB1, potential areas of non-compliance have been highlighted.

Note:

- ATM is the total mass of the trailer when carrying the maximum load recommended by the trailer manufacturer.

Purpose

The purpose of this Bulletin is to highlight these potential areas of non-compliance and provide guidance in compliance with VSB1. This Bulletin should be read in conjunction with VSB1 and other applicable references.

The potential areas of non-compliance include:

- | | | |
|----|--------------------------------------|-------------------|
| 1. | Trailer Identification Plates | (VSB1 Section 7) |
| 2. | Lighting | (VSB1 Section 13) |
| 3. | Braking Systems | (VSB1 Section 15) |
| 4. | Tow Couplings | (VSB1 Section 16) |
| 5. | Safety Chains | (VSB1 Section 16) |
| 6. | Axle Ratings | (VSB1 Section 19) |
| 7. | Trailer Dimensions | (VSB1 Section 21) |

Vehicle Examiners who are approved to carry out compliance checks or registration renewal inspections on light trailers must not pass light trailers for registration unless the trailer complies with VSB1, as applicable.

1. Vehicle or Trailer Identification Plate

All new trailers must have a vehicle identification plate (compliance plate) securely affixed.

The trailer manufacturer (person who built or assembled the trailer) must affix a vehicle plate to the trailer in a prominent position.

The vehicle plate must be of durable, non-corrosive metal and must be affixed to the trailer in a position where it may be readily examined and where it will be protected from damage by weather and debris (i.e. stones, etc).

The vehicle plate must be permanently affixed – e.g. pop rivets, hammer drive screws or welding. Affixing plates with adhesives is not acceptable.

Vehicle plates are available from any Service Tasmania outlets at a cost of \$2.00. A sample vehicle plate is attached below.

MANUFACTURER	TYRE SIZE
TRAILER MODEL	COLD INFLATION PRESSURE kPa
DATE OF MANUFACTURE	TYRE LOAD RATING Kgs
AGGREGATE TRAILER MASS kg	The tyres fitted to this vehicle shall have a speed category at least equal to the recommended maximum vehicle operating speed km/hr
V.I.N.	This trailer was manufactured to comply with the Motor Vehicle Standards Act 1989.

Note:

- The necessary trailer information will need to be added (i.e. stamped or engraved) to the vehicle plate by the trailer manufacturer.
- A vehicle plate is not required for a trailer manufactured prior to the application of VSB1.

2. Lights and Reflectors

- a. Trailers exceeding 2.1 metres in width require side marker lamps (clearance lights).
- b. Lamps on a trailer must not show red light to the front or white light to the rear (except reverse lamp).
- c. When fitting reflectors:
 - white to the front;
 - amber to the side; and
 - red to the rear (usually incorporated in the tail light assembly).
- d. If using a light board, red reflectors are still required on the rear of the trailer itself.
- e. Rear lamps and number plate are to be clearly visible from the rear at all times.

3. Braking Systems

Single-axle trailers with a Gross Trailer Mass (GTM) not exceeding 750kg do not require brakes.

Trailers up to 2000kg GTM (except single-axle trailers with GTM not exceeding 750kg) must have brakes operating on at least one axle which can be an 'over-run' braking system.

Trailers over 2000kg GTM must have brakes operating on all wheels which must be a 'break-away' braking system where the trailer brakes are activated if the trailer detaches from the towing vehicle.

Note:

- Two axle trailers with axle centres spaced less than one metre apart are regarded as a single axle.
- Gross Trailer Mass (GTM) is the mass transmitted to the ground by the tyres of the trailer when coupled to a towing vehicle and carrying the maximum load recommended by the manufacturer approximately uniformly distributed over the load bearing area.

4. Tow Couplings - General

Trailers up to 3500kg Aggregate Trailer Mass (ATM) must have a quick release coupling which is designed to be engaged and disengaged without the use of tools.

It must be of a positive locking type with provision for a second independent device. The locking must be readily verifiable by visual inspection.

For trailers with an ATM greater than 3500kg, refer directly to ADR 62/01 or ADR 62/02 "*Mechanical Connection Between Vehicles*", which can be found at the following website http://www.infrastructure.gov.au/roads/vehicle_regulation/bulletin/index.aspx

Tow Coupling Attachment

Tow couplings shall be attached in accordance with the manufacturer's instructions and specifications to include:

- Grade, dimension and tightening torque of attaching bolts (where applicable);
- Weld size and weld procedure (where applicable); and
- Recommended attaching position.

Note:

- Where the tow coupling prohibits welding as a method of attachment to the drawbar, an alternative method of attachment must be used (i.e. nut and bolts).

Tow Couplings – 50mm Ball Type Coupling Body Markings (up to 3500kg ATM)

Clause 12.4 of ADR 62 provides for three marking options for 50mm Coupling Bodies:

Option 1 Australian Standards "AS 4177-2004 Caravan and towing components"

Markings complying with AS 4177-2004 shall be legibly and permanently marked with the following information (characters must be no less than 5mm in height):

- a. The manufacturer's name or trademark;
- b. The mark '50' to indicate the size of towball for which it is intended;
- c. Maximum rating in kilograms, e.g. 750kg, or 2000kg, or 3500kg;
- d. A code to indicate serial number, batch, production date, or similar; and
- e(i). The words 'DO NOT WELD' if the coupling is manufactured from non-weldable material; or
- e(ii). The words 'WELD ONLY' if the coupling body is specifically designed to be attached by welding only.

Option 2 Clause 12.4 of ADR 62 "Mechanical Connection Between Vehicles"

Markings complying with Clause 12.4 must be marked with the following:

- a. The manufacturer's name or trademark;
- b. Maximum allowable ATM rating in kilograms, e.g. 750kg, or 2000kg, or 3500kg; and
- c. The words "use with model (identified model)".

Option 3 ECE Regulation R55/- Couplings.

Coupling complying with ECE RR55/- must be marked with the following:

- a. The manufacturers name and trademark;

- b. The mark "B" or "B50X";
- c. The "D" rating for the coupling; and
- d. The mark "S" followed by the permissible static vertical load in Kg.

5. Safety Chains

Trailers with rigid drawbars (pig trailers) must be fitted with appropriately rated and identifiable safety chains in accordance with:

- For trailers with an ATM up to 3500kg (Table 1)
Australian Standards AS 4177 – 1994 or AS 4177 – 2004 "Caravan and light trailer towing components - Part 4 – Safety chains up to 3500kg capacity", or
- For trailers over 3500kg ATM (Table 2)
Australian Standards AS 2321-1979 or AS 2321-2006 "Short link chain for lifting purposes".

Note:

- For trailers with an ATM up to 3500kg, safety cable may be used in lieu of safety chain providing the load capacity of the safety cable is not less than that of a chain complying with AS 4177 – 2004 for the ATM of the trailer.

Safety Chain Matrix (Guide Only)

Table 1 - For trailers with an ATM up to 3500kg

ATM (kg)	Minimum Chain Link Diameter (mm)	Rating (kg)	Number of Chains (minimum)	Marking (1.5mm for chain ≤ 8.0mm) (2.0mm for chain ≥ 8.0mm)	Minimum Marking Frequency (link)
0 to 1000	6.3	1000	1	4177-10	4th
Up to 1600	8.0	1600	1	4177-16	4th
Up to 2500	10.0	2500	1	4177-25	4th
Up to 3500	13.0	3500	2	4177-35	4th

Table 2 - For trailers over 3500kg ATM

ATM (kg)	Minimum Chain Link Diameter (mm)	Break Load (kg)	Number of Chains (minimum)	Marking	Minimum Marking Frequency (link)
Up to 4500	6.0	4607	2	(Manufacturer's Mark), "T", "8", "80" or "800"	20 th or 1m

Safety Chain Markings - ATM not exceeding 3500kg

The marking on complying chain is repeated at intervals not exceeding 4 links and the characters on the links are at least 1.5mm high (chains less than 8.0mm link diameter) and not less than 2 mm high (chains 8.0mm and above).

Safety Chain Markings - ATM exceeding 3500kg

Each length of chain shall be permanently and legibly marked at intervals of not more than 20 links or one metre with the marking being either raised or indented.

Towbar and Drawbar Attachment

- The safety chain must be attached to the trailer as near as practicable to the coupling to retain connection to the towing vehicle and prevent the drawbar from hitting the ground in the event of coupling failure.
- Safety chains on a trailer with an ATM exceeding 3.5t must not be welded.
- Where welding is permitted (e.g. ATM less than 3.5t) to attach the safety chain to the drawbar, the weld must cover at least 50% of the length of the link and the adjoining link must be able to move freely within the welded link. **Grade "T" chain must not be welded.**
- The drawbar safety chain attachment point should not come in contact with the ground at any time.
- Rated bolts, chain shackles or other suitable fittings (i.e. hammerlocks) may be used as devices for connection on safety chains providing the device is of sufficient load capacity to match the rating of the safety chain.

Safety Chain Shackles

Markings complying with AS 2741-2002 "Shackles" shall be legibly and permanently marked with the following information:

- The manufacturer's name or trademark;
- Quality grade of the shackle, e.g. ("M" or "4", "S" or "6");
- Working Load Limit (WLL) or Rating; and
- Identification marking in order to correlate shackle to test certificate.

Table 3 - Safety Chain Shackle Matrix (Guide Only)

Diameter (mm)	WLL (kg)	Quality Grade Marking	Diameter (mm)	WLL (kg)	Quality Grade Marking
6	250	"M" or "4"	16	1500	"M" or "4"
	500	"S" or "6"		3200	"S" or "6"
8	750	"S" or "6"	19	2000	"M" or "4"
				4700	"S" or "6"
10	500	"M" or "4"	22	3000	"M" or "4"
	1000	"S" or "6"		6500	"S" or "6"
11	1500	"S" or "6"	25	3800	M or 4
				8500	"S" or "6"
13	750	"M" or "4"	29	5000	M or 4
	2000	"S" or "6"		9500	"S" or "6"

Note:

- Pin diameter will be greater than the diameter of the shackle material.
- Same size shackles of different quality grades will have a different WLL (i.e. 6mm "S" grade shackle has a greater WLL than a 6mm "M" grade shackle).

- Stainless steel shackles are unsuitable for trailer use due to the material's general low resistance to bending stresses.
- "S" or "6" grade "D" Shackles bear similar characteristics to "S" or "6" grade "Bow Shackles".

6. Axle Rating (including wheels and tyres) and Suspension

Where two or more axles are fitted within an axle group, the axles must be related to each other through a load-sharing suspension.

This requirement does not apply to a close coupled axle group providing the load carrying capacity of each axle in the axle group, including the wheels and tyres fitted to each axle, is at least 120% of the ATM of the trailer.

A close coupled axle group is:

Axle Group	Number of Axles	Extreme Axle Spacing
Single Axle	2	$\leq 2.0\text{m}$
Tandem Axle	3	$\leq 3.2\text{m}$
Triaxle	4	$\leq 4.0\text{m}$

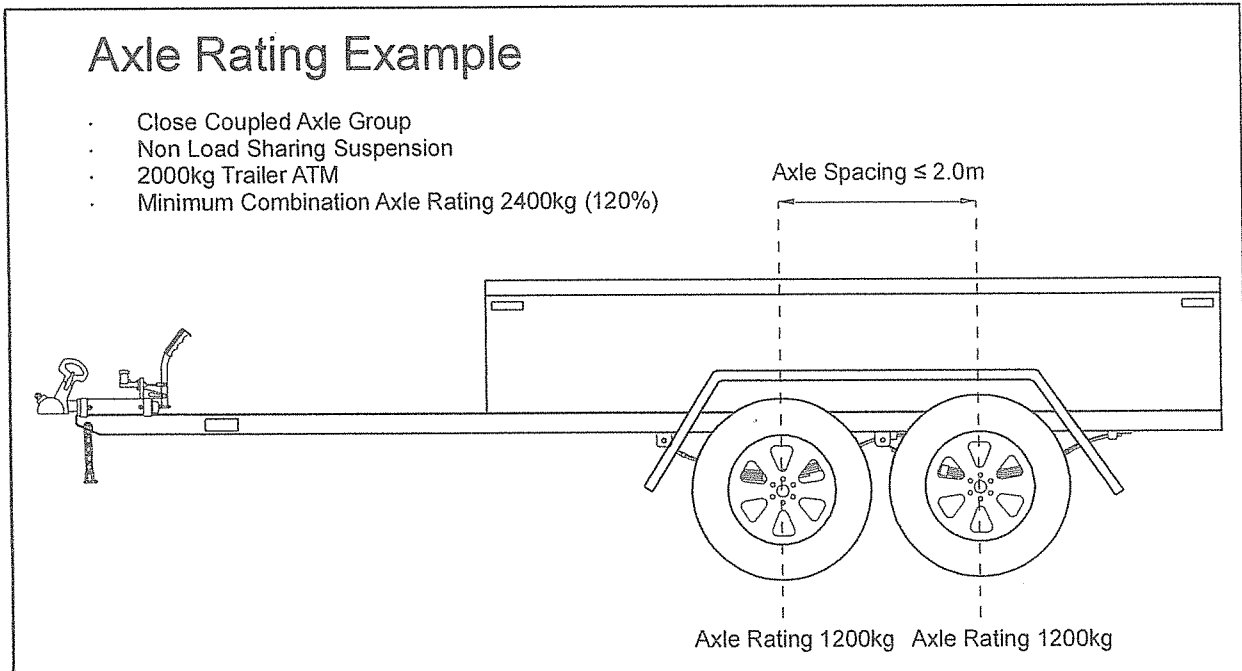

7. Maximum Trailer Dimensions (Pig Trailers)

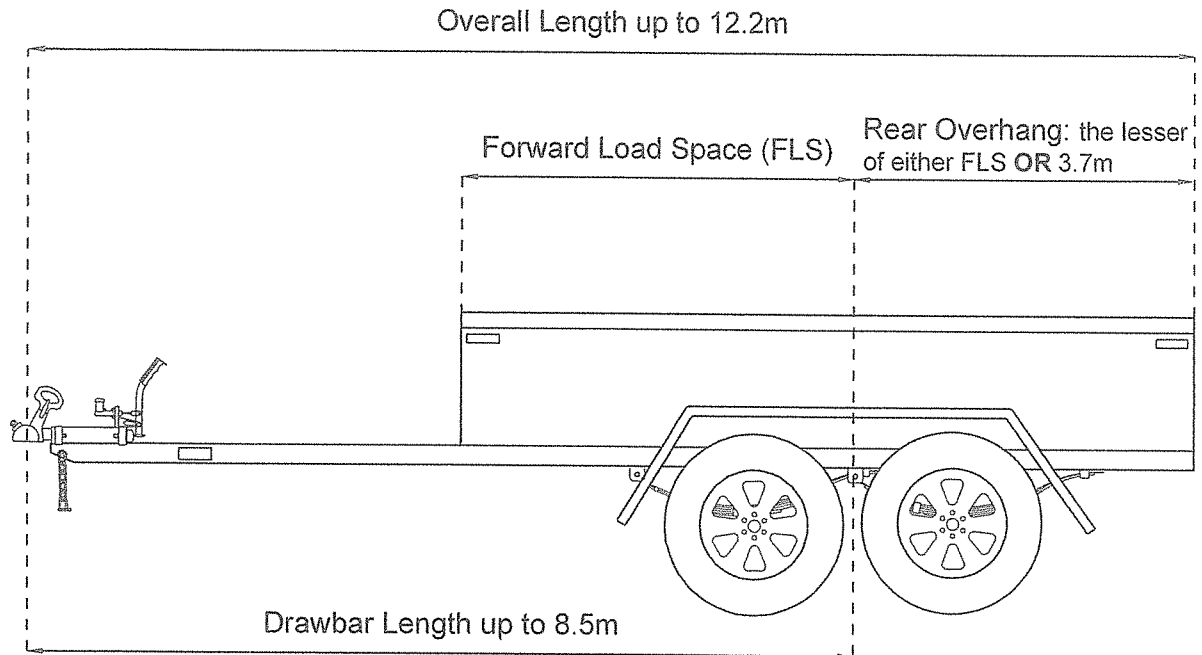

Note:

- Trailer width is measured across the body including wheel guards, but excluding signalling devices and side-mounted lamps.
- Trailers manufactured to exceed dimension limits (i.e. aeroplane glider trailers) will require approval from the Commonwealth Department of Infrastructure, Transport, Regional Development and Local Government – refer VSB 1.
- For more information on dimension limits, refer to Information Bulletin V13 "Vehicle Dimensional Limits (Including Load)".

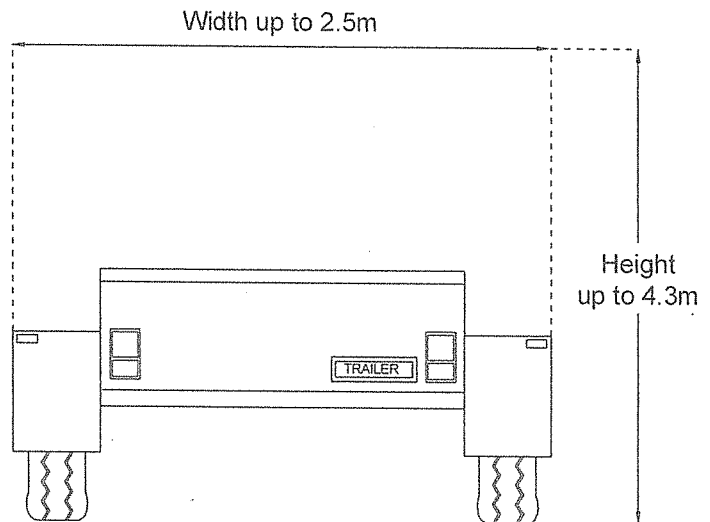

8. STRUCTURAL REQUIREMENTS

There are no specific body structural requirements, but the trailer must be safe and fit for service.

Note:

- It is suggested as a minimum that the manufacturer should be able to demonstrate that the structure is capable of supporting the designed payload with a safety factor of at least 3 for highway use and a safety factor of 5 for off road use.
- Drawbar strength refer to VSB1 section 16.1

Weblinks and References

- **Vehicle Standards Bulletin (VSB) 1 – Building Small Trailers**
http://www.infrastructure.gov.au/roads/vehicle_regulation/bulletin/vsb1/index.aspx
 - **Australian Design Rules (ADR) 62/01 & 62/02 - “Mechanical Connection Between Vehicles”**
<http://www.comlaw.gov.au/comlaw/management.nsf/lookupindexpagesbyid/IP200614283?OpenDocument>
<http://www.comlaw.gov.au/comlaw/management.nsf/lookupindexpagesbyid/IP200731792?OpenDocument>
 - **Information Bulletin V13 “Vehicle Dimensional Limits (Including Load)”**
<http://www.nt.gov.au/transport/mvr/vehiclestandards/infobulletins/ibv13.pdf>
 - **Information Bulletin V65 “Northern Territory Requirements for A-Frame Towing of Vehicles”**
<http://www.nt.gov.au/transport/mvr/vehiclestandards/infobulletins/ibv65.pdf>
-